

1. TYPE OF APPLICATION. PLEASE TICK

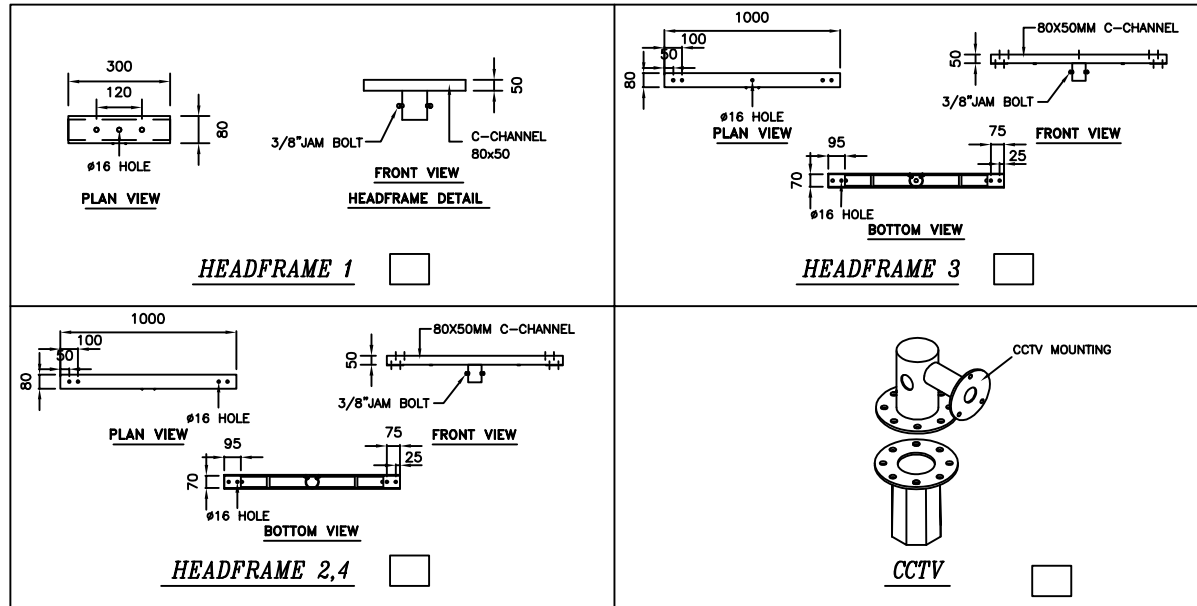

TECHNICAL SPECIFICATIONS

- THE COLUMNS ARE DESIGNED TO WITHSTAND MAXIMUM WIND SPEED OF 35 m/s (3-SEC GUST), TOPOGRAPHY, GROUND ROUGHNESS & STATISTICAL FACTOR OF 1.0.
- COLUMNS ARE MANUFACTURED IN COMPLIANCE TO BRITISH STANDARD BS EN 40.
- MATERIALS USED FOR COLUMNS ARE COMPLIANCE TO BS EN 10025 S275JR.
- COLUMNS ARE LONGITUDINALLY SEAM WELDED CONFORM TO BS 1011-1 BY AUTOMATIC CONTINUOUS METAL INERT GAS (MIG) PROCESS.
- COLUMNS ARE ANTI-CORRODED BY HOT-DIP GALVANIZED, COMPLIANCE TO GALVANIZING STANDARD BS EN ISO 1461
- ALL DIMENSIONS ARE IN (mm), UNLESS OTHERWISE SPECIFIED.
- ALL MATERIAL TOLERANCES ARE ACCORDANCE TO: BS EN 10029 (STEEL PLATE) BS EN 10255 (STEEL TUBE / HOLLOW SQUARE) BS EN 10056 (STEEL ANGLE)
- UNLESS OTHERWISE SPECIFIED, ALL DIMENSION WITHIN THIS DRAWING ARE AS PER GALVAPOLE STANDARD SPECIFICATION AND SUBJECTED TO TOLERANCE AS PER BS EN 40-2.

Lm (NOMINAL MOUNTING HEIGHT)

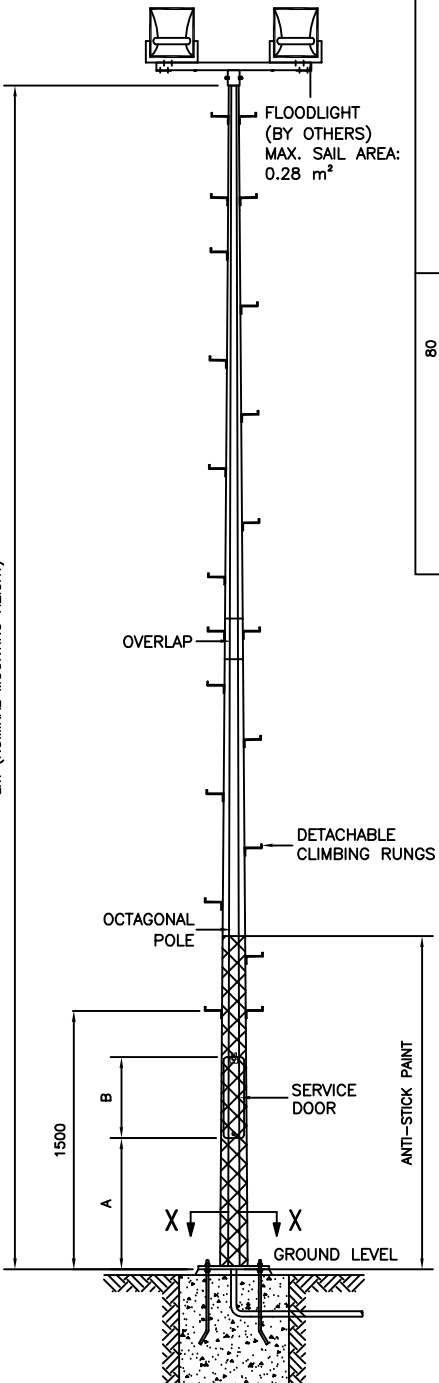

PLEASE TICK

2. SERVICE DOOR TYPE

STEEL	<input type="checkbox"/>
FIBER WITH _____ WORDING	<input type="checkbox"/>

3. SPECIAL DOOR HEIGHT "A"

2.0M FROM GROUND LEVEL	<input type="checkbox"/>
1.8M FROM GROUND LEVEL	<input type="checkbox"/>

4. ANTI-STICK PAINT

_____ M FROM GROUND LEVEL	<input type="checkbox"/>
---------------------------	--------------------------

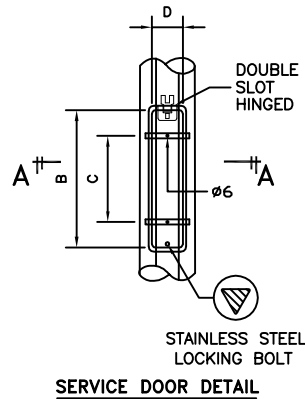

SERVICE DOOR DETAIL

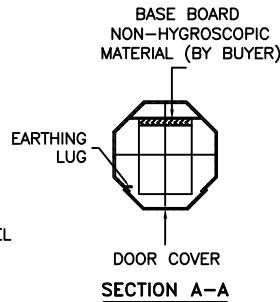

SECTION A-A

5. COLUMN DETAIL. PLEASE TICK

TICK	Lm	STANDARD SERVICE DOOR DETAIL				FLANGE DETAIL				HOLDING BOLT		CLIMBING RUNG QUANTITY	OVERLAP
		A	B	C	D	SQ	C-C	ELONGATED		ØD	E		
<input checked="" type="checkbox"/>	3	305	305	150	72	300	220	25	45	Ø20	450	7	-
	4	305	305	150	100	300	220	25	45	Ø20	450	9	-
	5	305	305	150	110	300	220	25	45	Ø20	450	11	-
	6	305	450	300	110	300	220	25	45	Ø20	450	13	250
	7	610	450	300	110	300	220	30	50	Ø24	570	17	250
	8	610	450	300	110	335	260	30	50	Ø24	570	19	250
	10	610	450	300	110	400	300	30	50	Ø24	570	24	250
	12	610	450	300	110	400	300	30	50	Ø24	570	27	250

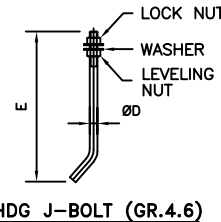

HDG J-BOLT (GR.4.6)

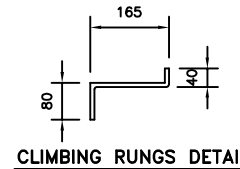

CLIMBING RUNGS DETAIL

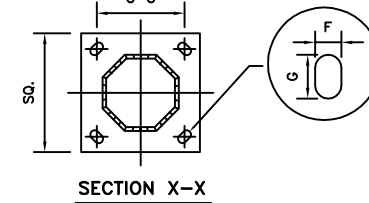

SECTION X-X

GALVAPOLE INDUSTRIES SDN. BHD.
 9, JALAN KECAPI 33/2,
 ELITE INDUSTRIAL ESTATE
 JALAN BUKIT KEMUNING,
 40350 SHAH ALAM, SELANGOR
 MALAYSIA
 Tel : +603-51213300
 Fax : +603-51212828
 Website : www.galvapol.com
 Email : sales@galvapol.com

CLIENT : -
 PROJECT : -
 DATE : _____ DRAWN BY : _____
 DRAWING TITLE :
**CLIMBING RUNG
 COLUMN FLANGE MOUNTED**

CAD FILE : FLCRR FM STD ISO
 CHECK BY : _____
 APPROVE BY : _____
 SCALE : N.T.S REVISION : 00
 THIS DRAWING BELONGS TO THE PROPERTY OF GALVAPOLE INDUSTRIES SDN. BHD. IT MUST NOT BE REPRODUCED WITHOUT OWNER'S PRIOR CONSENT IN WRITING.