

8M NOMINAL MOUNTING HEIGHT

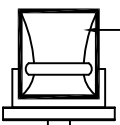

FLOODLIGHT  
(BY OTHERS)

HEADFRAME FOR  
1 FLOODLIGHT

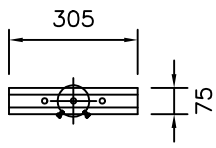

PLAN VIEW

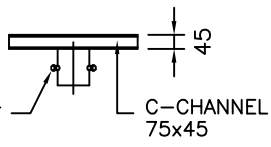

FRONT VIEW  
HEADFRAME DETAIL

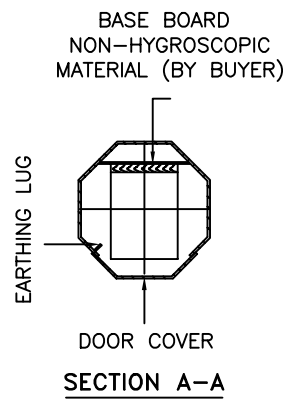

BASE BOARD  
NON-HYGROSCOPIC  
MATERIAL (BY BUYER)

EARTHING LUG

DOOR COVER

SECTION A-A

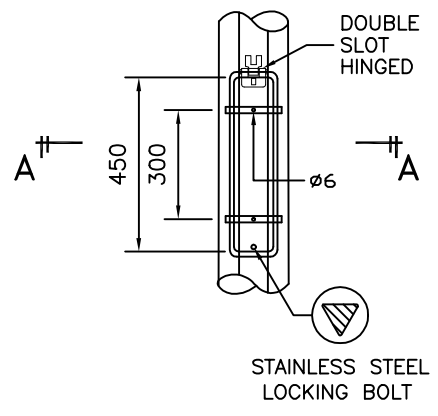

DOUBLE SLOT  
HINGED

STAINLESS STEEL  
LOCKING BOLT

SERVICE DOOR DETAIL

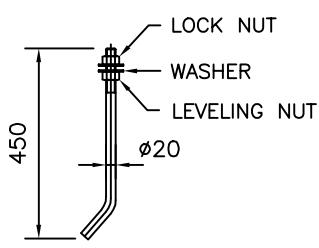

J-BOLT

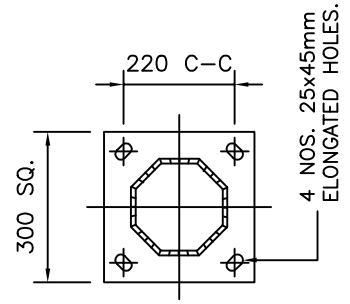

SECTION X-X

4 NOS. 25x45mm  
ELONGATED HOLES.

**TECHNICAL SPECIFICATIONS**

- THE COLUMNS ARE DESIGNED TO WITHSTAND WIND SPEED OF 35M PER SECOND, TOPOGRAPHY, GROUND ROUGHNESS & STATISTICAL FACTOR OF 1.0.
- COLUMNS ARE MANUFACTURED IN COMPLIANCE TO BRITISH STANDARD BS EN 40.
- MATERIALS USED FOR LIGHTING COLUMNS ARE COMPLIANCE TO BS EN 10025 S275 /JIS G3101 SS400.
- LIGHTING COLUMNS ARE LONGITUDINALLY SEAM WELDED CONFORM TO BS 5135 BY AUTOMATIC CONTINUOUS METAL INERT GAS (MIG) PROCESS.
- COLUMNS ARE ANTI-CORRODED BY HOT-DIP GALVANIZED, COMPLIANCE TO GALVANIZING STANDARD BS EN ISO 1461
- SERVICE DOOR DIMENSIONS ARE GIVEN AS A GUIDE ONLY. THE ENGINEER MUST SATISFY HIMSELF THAT DIMENSIONS GIVEN ARE ADEQUATE FOR THE INSTALLATION OF THE REQUIRED CONTROL GEAR.
- ALL DIMENSIONS ARE IN (mm), UNLESS OTHERWISE SPECIFIED.

**GALVAPOLE INDUSTRIES SDN. BHD.**  
  
 9, JALAN KECAPI 33/2,  
 ELITE INDUSTRIAL ESTATE  
 JALAN BUKIT KEMUNING,  
 40350 SHAH ALAM, SELANGOR  
 MALAYSIA  
 Tel : 603-51213300  
 Fax : 603-51212828  
 Website : www.galvapole.com  
 Email : sales@galvapole.com

CLIENT : -		DRAW NO : 8M/FLC/HF-1/FM/R0	
PROJECT : -		FILE NAME : FLC STD ISO	
DATE : 17-03-2010	DRAWN BY : A.D	CHECKED BY : CCC	SCALE : N.T.S
DRAWING TITLE : <b>8M FLOODLIGHT COLUMN HF-1 fm</b>		APPROVED BY : CCC	A4 SIZE

THIS DRAWING IS THE PROPERTY OF GALVAPOLE INDUSTRIES SDN. BHD. AND MUST NOT BE REPRODUCED WITHOUT THEIR PRIOR CONSENT IN WRITING.